

# BA 2002 Battery Vacuum

ALL YOU NEED TO  
VACUUM ON THE GO.



## Ideal Applications:

- Remote Location Cleanup
- Distribution Centers
- Large Warehouses
- Parking Lots
- Indoor Remote Locations

# Ruwac

We vacuum everything.

[www.WorkDustFree.com](http://www.WorkDustFree.com)

Call Toll Free: 1-800-614-9598 (U.S. only)



# BA 2002 Battery Vacuum

Take portability to a whole new level with Ruwac's cordless Battery Vacuum. Engineered to provide vacuum power in places where electricity isn't an option, the Battery Vac is ideal for indoor use without pesky cords or harmful emissions from propane or gasoline-powered systems.

Rechargeable battery pack powers a multi-stage continuous duty turbine. A universal Ruwac inlet can adapt to a variety of hoses and accessories for general cleanup, overhead cleaning or floor tools.

Ruwac's state-of-the-art filtration system features 99.9% efficiency at 0.5 microns. The manual filter cleaning assembly preserves filter life with less maintenance. Optional HEPA filters are 99.997% efficient at 0.3 microns to ensure absolute filtration.

Modular housing is extremely durable; it will never dent or rust. Compression cast composite fiberglass housing is chemically neutral and break resistant.

To empty, simply use the foot lever actuated, 9 gallon drop down dust pan. Next to the heavy duty, self-locking double casters, the quick release makes emptying collected waste simple and quick.

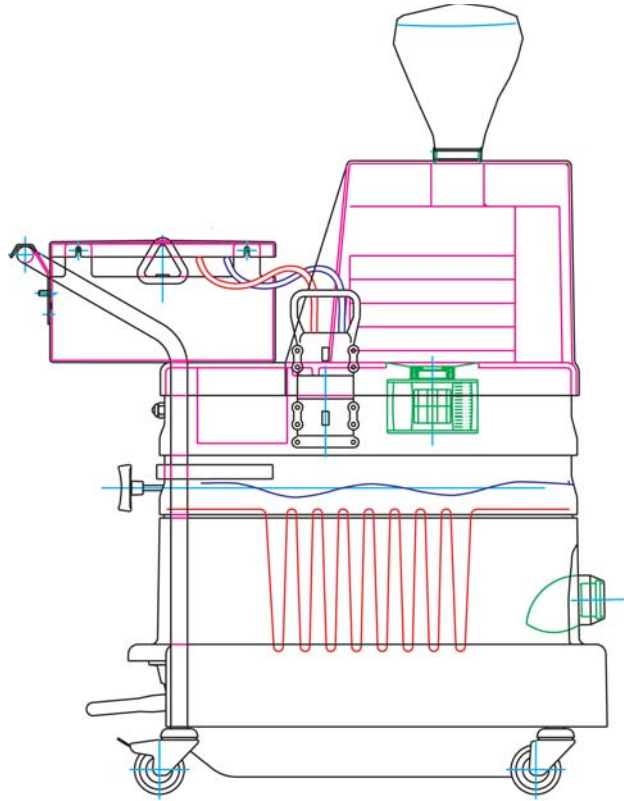

Engineered to provide power in applications where electricity isn't an option.

## FEATURES



State of the art filtration system cleans effectively and efficiently.

Technical Data	BA 2002
Voltage	48 [(4) 12 Volt Batteries]
Amperage	38
Vacuum Pressure (Hg")	5.7
Air Movement (CFM)	150
Filter Area (ft <sup>2</sup> )	13 ft <sup>2</sup>
Filter Efficiency	99.9% @0.5 microns
Inlet	2"
Weight (lbs.)	267
L x W x H (in.)	32 x 20 x 41"

Specifications are subject to change without notice.



Battery pack features a space-saving design to keep vacuum small and portable.



Foot lever actuated drop down dust pan allows for easy waste removal.



Low inlet inhibits machine from tipping over during use.



Compression cast composite housing is modular to accommodate additional filters.



All models are HEPA - ready, should your application require absolute filtration.



*Real Vacuums for Real Applications.*

Latta Equipment  
330 East Hebron St. Ste J  
Charlotte, NC 28273

Tel (704) 752-7944  
Fax (704) 414-6811  
[www.WorkDustFree.com](http://www.WorkDustFree.com)

